

IW-SERIES

IWQ-30/IWQ-150 IWX-30/IWX-150 IWB-6/IWB-30/IWB-150

Water-proof digital platform scale

Accurate under any conditions



Conforms to IP-67: Doesn't get rust even under harsh operating environment

Constructed of water-proof stainless steel, the versatile IW series is ideal for food processing applications – from agricultural and fishery industries to wholesaling and retailing industries

Water-proof Design Conforms to IP-67*1
The IW-Series meets IP-67 requirements, even allowing washdown for highest sanitary conditions.

Sturdy, Stain, Chemical, and Corrosion Resistant Water-proof Load Cell Conforms to IP-67.

This outstandingly durable weighing unit can be washed and sprayed with water, allowing for easy cleaning. For the first time in the industry the load cell has been coated with acrylic resin to make it completely water-proof. This is the same kind of treatment used on aluminum sash.



Checkweighing Function
Used as a checkweigher, upper and lower weight limits can be set. The scale alerts the operator when a product is not within the specified range. The IW Series improves quality control and increases productivity by eliminating products of insufficient weight and categorizing products by weight.

RS-232C Interface
The IW Series connects to other equipment via an RS-232C interface, providing streamlined information management.

Multi Interval
Weighing range changes depending on product weight. No need to use several scales for different weighing capacities.



Three Display Windows and Easy Operating Keypad



Upper and lower weight limits can be set to check if the product weight is within the specified range. Suitable for controlling the filling quantity of packed food, etc.

The numeric keypad allows easy operation in counting mode. Unit weight and total weight can be displayed at the same time.

The versatile IW Series provides fast, accurate counting. Simply change modes to turn the unit into a counting scale, easy-to-preset, the scale quickly computes weight per piece after samples are placed on the counting plate.

IWQ-30



IWQ-150

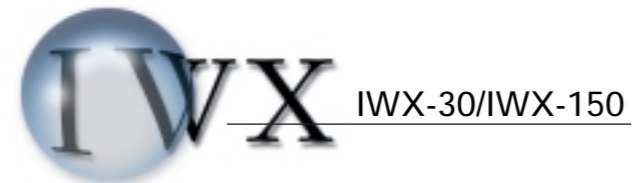

Large Fluorescent Display



Large, clear fluorescent display (character height: over 30 mm)

Featuring large digits, the bright fluorescent display provides superior visibility under any conditions.

Has weight checking function for accurate weighing.

IWX-30



IWX-150

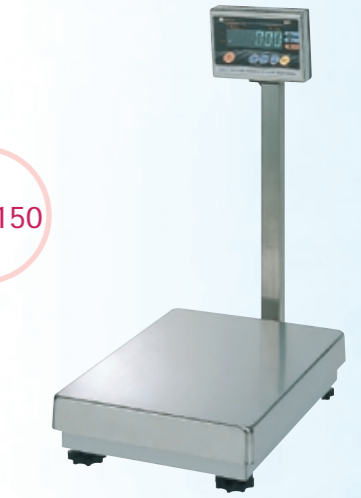

1,000-hour Battery Life



Can be operated for 1,000 hours*2 with only 2 size D alkaline dry batteries. (AC adapter can be used too.)

Has weight checking function for accurate weighing.

Large character height (36.5 mm)

IWB-6



IWB-30



IWB-150



Dimensions

Unit : mm (inch)

IWQ-30

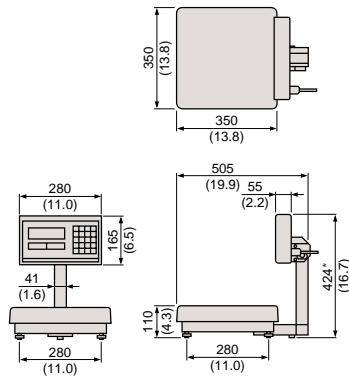

IWQ-150

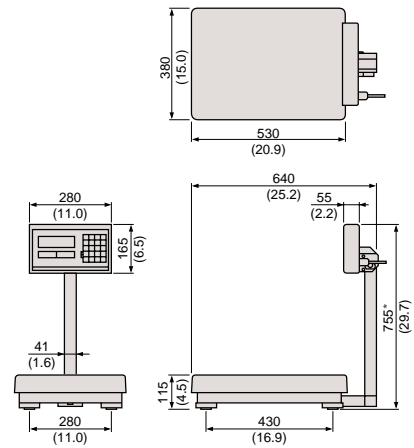

* Height in Australian specification IWQ-30: 755 mm (29.7 in.) /IWQ-150: 900 mm (35.4 in.)

IWX-30

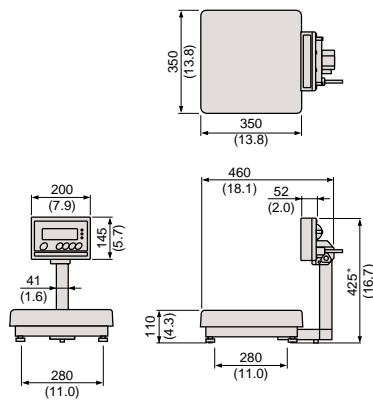

IWX-150

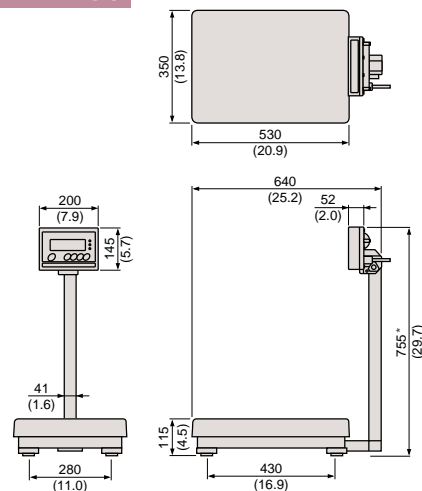

* Height in Australian specification IWX-30: 755 mm (29.7 in.) /IWX-150: 900 mm (35.4 in.)

IWB-6

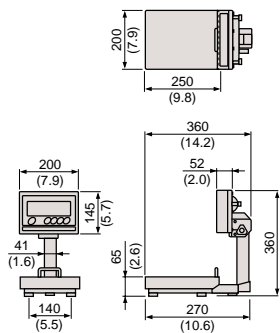

IWB-30

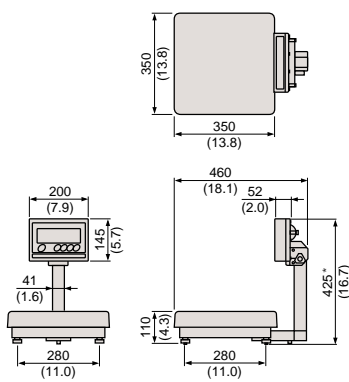

IWB-150

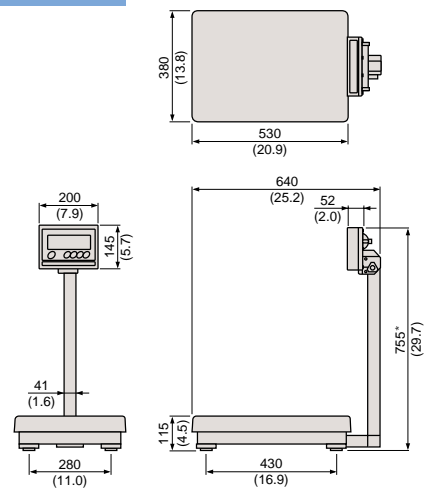

* Height in Australian specification IWB-30: 755 mm (29.7 in.) /IWB-150: 900 mm (35.4 in.)

Specifications

Models	IWQ-30	IWQ-150	IWX-30	IWX-150	IWB-6	IWB-30	IWB-150
Capacity	30 kg	150 kg	30 kg	150 kg	6 kg	30 kg	150 kg
Minimum Graduation	0.005 kg (0-15 kg)	0.02 kg (0-60 kg)	0.005 kg (0-15 kg)	0.02 kg (0-60 kg)	0.001 kg (0-3 kg)	0.005 kg (0-15 kg)	0.02 kg (0-60 kg)
	0.01 kg (15-30 kg)	0.05 kg (60-150 kg)	0.01 kg (15-30 kg)	0.05 kg (60-150 kg)	0.002 kg (3-6 kg)	0.01 kg (15-30 kg)	0.05 kg (60-150 kg)
	Multi interval						
Display	Fluorescent				LCD		
Weight Check	over, accept, under						
Weight	10 kg	17.4 kg	9.4 kg	16.8 kg	4.7 kg	Excluding 2 dry batteries	
						9.1 kg	16.5 kg
Waterproof Construction	IP-67 (console: IP-65)		IP-67				
Power Supply	AC 100 V ~ 240 V +/-10 %, 50/60 Hz				2 dry batteries or AC adapter		
Standard Interface	External buzzer or RS232C and relay output signal (except IWB-Series)						
Option	RS232C cable, relay output box (except IWB-Series)						
Safety Approval	UL, CE, c-Tick						

*1. Console for IWQ series is IP-65.

*2. Battery performance varies depending on its manufacturer, preservation, temperature, and condition of usage.



Design and specifications are subject to change without notice.



ISHIDA CO., LTD.

44 SANNO-CHO, SHOGOIN, SAKYO-KU
 KYOTO, 606-8392 JAPAN
 PHONE : 81-75-771-4141
 FACSIMILE: 81-75-751-1634
 URL: <http://www.ishida.co.jp/english>